

**COUNTY OF IMPERIAL
DEPARTMENT OF PUBLIC HEALTH SERVICES
ENVIRONMENTAL HEALTH & CONSUMER PROTECTION SERVICES
MAIN STREET PROFESSIONAL BUILDING
797 Main Street, Suite B
El Centro, CA 92243
(760) 336-8530**

SITE PLAN INFORMATION

A site plan is required to be submitted with any septic system permit application, whether for a new installation or repair of an existing system.

The purpose of the site plan is to demonstrate to this department that the intended work will meet all of the setback requirements.

The site plan is to be an accurate depiction of the applicant's intentions. Therefore, the applicant should not assume anything about the information required but obtain accurate measurements and consult with his contractor before making the plan. The plan must be drawn approximately to scale.

The site plan shall contain the following on-site information:

1. Property lines.
2. Structures (existing & proposed).
3. Storm water retention areas (if applicable).
4. Driveways and Parking areas.
5. Water systems (wells and cisterns).
6. All water pipes (indicate whether pressurized & non-pressurized).
7. Septic systems (existing and proposed).
8. Agricultural tile lines within 10 feet of the proposed septic system (if applicable).
9. Dedicated area to relocate the leach field in the event of failure of the original field.
10. Canals, streams, ditches.
11. Trees (existing or proposed).

The site plan shall also indicate the distance of non-pressurized water pipes, water wells, water cisterns, canals, streams, and ditches when these are located on properties immediately adjacent to the site. The on-site sewage disposal system is subject to the same setbacks from off-site features as it is from on-site features as shown in the following table.

SUMMARY TABLE OF REQUIRED SETBACKS			
MINIMUM HORIZONTAL DISTANCE IN CLEAR REQUIRED FROM	BUILDINGSEWER	SEPTICTANK	DISPOSALFIELD
BUILDING OR STRUCTURES ^a	2 FEET	5 FEET	8 FEET
PROPERTY LINE ADJOINING PRIVATE PROPERTY	CLEAR ^b	5 FEET	5 FEET
WATER SUPPLY WELLS	50 FEET ^c	50 FEET	100 FEET
STREAMS, CANALS, CISTERNS, DITCHES, DETENTION BASINS	50 FEET	50 FEET	50 FEET
TREES		10 FEET	10 FEET
SEEPAGE PITS OR CESSPOOLS		5 FEET	5 FEET
DISPOSAL FIELD		5 FEET	4 FEET ^d
ON SITE DOMESTIC WATER SERVICE LINE	1 FOOT ^e	5 FEET	5 FEET
DISTRIBUTION BOX			5 FEET
PRESSURE PUBLIC WATER MAIN	10 FEET ^f	10 FEET	10 FEET
NON-PRESSURIZED WATER LINES	50 FEET	50 FEET	50 FEET

ENDNOTES TO THE TABLE

When disposal fields and/or seepage pits are installed in sloping ground, the minimum horizontal distance between any part of the leaching system and ground surface shall be fifteen (15) feet.

- a Including pools, porches and steps, whether covered or uncovered, breezeways, roofed porte-cocheres, roofed patios, car ports, covered walks, covered driveways, and similar structures or appurtenances.
- b See also Section 315(c) of the Uniform Plumbing Code.
- c All drainage piping shall clear domestic water supply wells by at least fifty (50) feet. This distance may be reduced to not less than twenty-five (25) feet when the drainage piping is constructed of materials approved for use within a building.
- d Plus two (2) feet for each additional foot of depth in excess of one (1) foot below the bottom of the drain line. (See also Section 16).
- e See Section 1108 of the Uniform Plumbing Code.
- f For parallel construction - For crossings, approval by the Health Department shall be required.

Example Site Plan

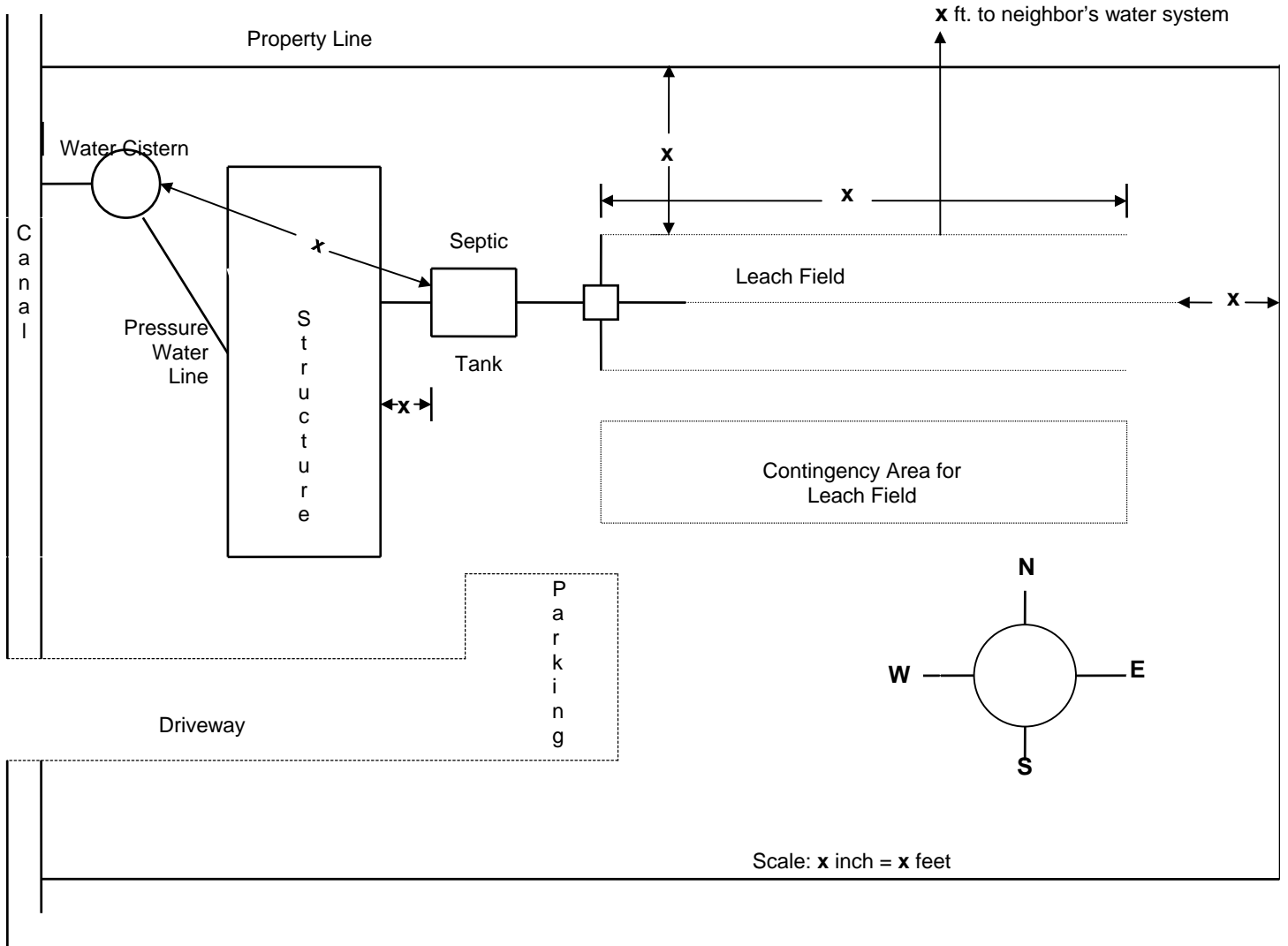

The site plan submitted will show the measurements as indicated by "x" in the above example.

The scale of the site plan must be indicated. The site plan must show how it is oriented relative to North.