

PLAN REVIEW GUIDE FOR RETAIL FOOD FACILITIES



PLAN REVIEW INFORMATION

The following documents are required at the time of the filing:

1. Plan Review Application
2. Commercial Hood Mechanical Exhaust, Data Information Sheet
3. 3 full copies of the plans
4. Menu
5. Plan Review fee.

Fee:

If the projected cost of the project is under \$5,000.00:

- The fee will be \$250.00

If the projected cost of the project is \$5,001.00 > but under \$30,000.00:

- The plan review deposit is \$1,000.00

If the projected cost of the project is over \$30,001.00:

- The plan review deposit is \$1,500.00

Please note that ALL plan reviews are charged on a time and materials basis for actual costs incurred by the Division. If the amount of the deposit proves inadequate to cover costs, the account will be billed the remaining balance before completion of the plan review. Project approvals will not be issued until all fees are paid. Any remaining deposit balance after completion of the plan review will be credited or refunded.

For more information, please visit our website [here](#).

TABLE OF CONTENTS

PLAN CHECK CONSTRUCTION/REMODEL GUIDE	4
CONSTRUCTION REQUIREMENTS FOR RETAIL FOOD FACILITIES	4
OVERVIEW	4
DEFINITIONS	4
PLAN CHECK SITE CONSULTATION	5
WHEN FOOD FACILITIES ARE REQUIRED TO SUBMIT PLANS	5
CONSTRUCTION PLAN CHECK APPROVAL PROCESS	5
CONSTRUCTION PLAN SUBMITTAL REQUIREMENTS	6
CONSTRUCTION DETAIL REQUIREMENTS	6
1. FULL ENCLOSURE:	6
2. FLOORS:	6
3. FLOOR DRAINS:	6
4. WALLS & CEILINGS:	7
5. LIGHTING:	7
6. VENTILATION:.....	7
7. OUTDOOR BARBEQUE/WOOD-BURNING OVEN:.....	8
8. FLIES, RODENT AND VERMIN EXCLUSION:	8
9. WINDOWS:	8
10. EXTERIOR, EXIT, AND CARGO DOORS:	8
11. EXTERIOR VENTS AND CONDUITS:	9
12. GARBAGE AREA:	9
13. TOILET FACILITIES:.....	9
14. EMPLOYEE CHANGING ROOM:.....	9
15. EQUIPMENT STANDARD:.....	9
16. SINKS:	10
17. FOOD AND EQUIPMENT PROTECTION:	11
18. INSTALLATION OF EQUIPMENT:	12
19. STORAGE:.....	12
20. PLUMBING AND GAS:.....	12
21. ELECTRICAL SUPPLY:	12
22. WATER SUPPLY:	13
23. SEWAGE DISPOSAL, GREASE TRAPS AND INTERCEPTORS.....	13
GUIDELINES FOR PRE-PACKAGED FOOD ONLY FACILITIES	14
FINAL APPROVAL REQUIREMENTS	15
WARNING.....	15
APPENDIX A	16
Commercial Hoods/Mechanical Exhaust Data Sheet.....	16
APPENDIX B	17
Commercial Water Heater Worksheet	17
Sizing Table for Gas Water Heaters	18
Sizing Table for Electric Water Heaters	19
APPENDIX C	21
Sample Floor Plan- Restaurant	21
Equipment Schedule Sample	22
Equipment Schedule	23
Finish Schedule.....	23
APPENDIX D	25
Approved Floor Coverings	25
APPENDIX E	27
Plan Submittal Construction/Remodel Checklist.....	27

PLAN CHECK CONSTRUCTION/REMODEL GUIDE

CONSTRUCTION REQUIREMENTS FOR RETAIL FOOD FACILITIES

OVERVIEW

This guide is based on requirements found in the California Retail Food Code (**CRFC**), Part 7 of the California Health and Safety Code. It is intended to serve as a general overview of the plan and construction requirements, and should not be considered all-inclusive. Please refer to the most current revision of CRFC for additional requirements and details at www.icphd.org. The website for the California Conference of Directors of Environmental Health at www.ccdeh.org also has guidelines, which may be of value to you.

Pursuant to the California Retail Food Code, Section 114380, (a) A person proposing to build or remodel a food facility shall submit complete, easily readable plans drawn to scale, and specifications to the enforcement agency for review, and shall receive plan approval before starting any new construction or remodeling of any facility for use as a retail food facility, (b) Plans and specifications may also be required by the enforcement agency if the agency determines that they are necessary to assure compliance with the requirements of this part, including, but not limited to, a menu change or change in the facility's method of operation.

This guide only encompasses the health aspects of construction, and should not be construed to include requirements of other agencies involved, such as the local Planning Departments, the local Building and Safety Departments, the local Fire Departments, and the local Water Districts. Contact the appropriate local agencies involved to obtain any permits and/or to clarify other local codes.

Approved plans are valid for one year after the approval date. New plans will be required to be submitted if no construction has begun one year from the date the plans were approved. Please contact our office for further information if the project has not begun construction within one year.

DEFINITIONS

A RETAIL FOOD FACILITY: A place where food is stored, prepared, served, packaged, transported, or otherwise handled for dispensing or sale directly to the consumer. This includes, but is not limited to, liquor stores, bakeries, grocery stores, meat markets, restaurants, cocktail lounges, soda fountains, coffee shops, vitamin stores, food or herbal supplement stores, school cafeterias (public and private), licensed healthcare facilities serving food, commissaries, mobile food facilities, temporary food facilities, vending machines which handle open food or potentially hazardous food, farm stands, etc. (**CRFC - 113789**)

NEW CONSTRUCTION:

- a. A building or structure being constructed as a brand new retail food facility **OR**
- b. An existing building or structure that is being converted into a retail food facility **OR**
- c. An existing retail food facility that has changed ownership and will undergo modifications.

REMODEL: Construction, renovation or repair to a food facility that holds a current valid Food Facility Permit, and requires a permit from the local building department. It shall involve but is not limited to structural alterations and the replacement, addition, relocation or significant modification of equipment or fixtures.

PLAN CHECK SITE CONSULTATION

A field inspection that determines if a food facility meets the current health code requirements or if plans would be required to be submitted to Plan Check for review and approval. A site evaluation can be arranged for the following circumstances. A fee is involved for this consultation.

- a. The food facility has been closed for 90 days or more, or the Health Permit has been revoked.
- b. There has been a change in the menu or the operation.
- c. Modifications have been made to the building structure.
- d. There has been alteration, replacement or addition of food equipment or added fixtures.

WHEN FOOD FACILITIES ARE REQUIRED TO SUBMIT PLANS

- a. Prior to a food facility being constructed.
- b. Prior to a permitted food facility being remodeled.
- c. If the food facility has been closed for 90 days or more (except seasonally operating facilities).
- d. When there is a change of ownership of an existing food facility and the facility will be modified (e.g. changing, adding or relocating equipment).
- e. Prior to a food facility changing its operation (e.g. changing from a limited menu to a full service operation).
- f. When a building permit is required (structural, plumbing, electrical, mechanical).

Note: Food facilities with only prepackaged, non-potentially hazardous foods that have less than 200 sq. ft. of food display and storage are not required to submit plans.

HOW LONG DOES THE PLAN REVIEW PROCESS TAKE?

Within twenty (20) working days (CRFC - 114380), you will be sent a letter indicating that the plans are approved or rejected. If the plans are rejected, the letter will include details on what needs to be changed or submitted in order to obtain approval.

Before commencing construction, approvals must be obtained from this Division, the local Building Official, and any other applicable authorities. **If any changes to the approved plans become necessary, revised plans shall be submitted for review and approval prior to construction.**

CONSTRUCTION PLAN CHECK APPROVAL PROCESS

1. Submit three (3) complete sets of plans, menu, and equipment specifications sheets to this Division. Plans to other agencies may be submitted at the same time. However, other agencies will not approve the plans until Environmental Health approves the plans.
2. Incomplete plans will slow down approval.
3. Once the plans are approved, it is your responsibility to contact our Division to schedule a 75% inspection, which is when flooring and plumbing are complete.
4. A final inspection will be conducted once construction is complete. At this inspection, the facility should be ready to open. All refrigerators and hot holding units are to be running and holding temperature; all soap and paper towel dispensers are to be full; hot and cold water are to be available; pass through windows are to function, etc. If the facility is not ready (e.g., a piece of equipment is not holding temperature), an additional inspection will have to be conducted at the current hourly fee.
5. Maintain a copy of the approved plans and specifications sheets on the job site until the facility passes its final inspection.
6. Any revisions to the original approved plans, including a change in equipment, shall be submitted to this Division for approval prior to the change being done.
7. When all agencies have approved the facility, a food facility health permit will be issued once a permit application is submitted with the permit fee and any outstanding fees are paid.

CONSTRUCTION PLAN SUBMITTAL REQUIREMENTS

Plans shall be easily readable, drawn to scale, (e.g. 1/4" = 1') and shall include:

1. Complete floor plan with plumbing, electrical, lighting and equipment details. Demolition plans may be required for the proposed remodel of an existing facility. Also, complete appendix B for sizing the water heater.
2. Complete mechanical exhaust ventilation plans including make-up air. Provide front, side and top view of the exhaust hood to scale. Indicate the type of comfort cooling in the building, e.g. "building is cooled by refrigerated air conditioning," "evaporative cooling," and locations of vents and restroom exhaust fans. Complete Appendix A if an exhaust hood will be installed.
3. Finish schedule for floors, walls, and ceilings that indicates the type of material, the surface finish, and the type and dimensions of coved base at the floor-wall juncture.
4. A site plan including proposed waste storage receptacle location. If applicable, this is to include location of common use restrooms and janitorial facilities.
5. Equipment manufacturer's specification sheets.
6. Copy of the proposed menu.
7. Source of potable water and method of sewage disposal.

CONSTRUCTION DETAIL REQUIREMENTS

The plans shall show and specify the following in detail:

1. FULL ENCLOSURE:

Each permanent food facility shall be fully enclosed in a building consisting of permanent floors, walls, and an overhead structure that meet the minimum standards as prescribed by this document (CRFC - 114266). Doors to the outside are to be self-closing, and close with gaps not to exceed 1/8" in order to exclude flies and other vermin. Refer to sections titled "Windows" and "Doors" for more information.

2. FLOORS:

The floor surfaces in all areas (except in sales and dining areas) where food is prepared, prepackaged, or stored, employee change rooms, where any utensil is washed, where refuse or garbage is stored, where janitorial facilities are located, and in all toilet and hand washing areas, shall be smooth and of durable construction and nonabsorbent material that is easily cleanable (impervious to water, grease and acid) (e.g. quarry tile or troweled epoxy, approved commercial grade sheet vinyl or other approved materials). **(CRFC - 114268) Note: Vinyl top set cove base is not acceptable.**

Indicate the floor finish will have a smooth surface under all equipment. These floor surfaces shall be coved at the juncture of the floor and wall with a three-eighths inch (3/8") minimum radius coving and shall extend up the wall at least four inches (4"), except in areas where food is stored only in unopened bottles, cans, cartons, sacks, or other original shipping containers.

3. FLOOR DRAINS:

Floor drains shall be installed in floors that are water-flushed for cleaning and in areas where pressure spray methods for cleaning equipment are used. Floor surfaces in these areas shall be sloped 1:50, which is approximately one-quarter inch (1/4") per foot toward the floor drains. It is advisable to install floor drains in restrooms whenever possible. Other agencies may also require floor drains, even in areas where floors are not water-flushed or where equipment is not pressure sprayed for cleaning. **(CRFC 114269)**

4. WALLS & CEILINGS:

The walls and ceilings of all rooms shall be of a durable, smooth, non- absorbent, easily cleanable surface except in the following areas: (a) bar areas in which only alcoholic beverages are sold or served directly to the consumers, except wall areas adjacent to bar sinks and areas where food is prepared; (b) areas where food is stored only in unopened bottles, cans, cartons, sacks, or other original shipping containers; (c) dining and sales areas;(d) offices; (e) restrooms used exclusively by the consumers, except that the walls and ceilings shall be of a nonabsorbent and washable surface. Acceptable materials are gloss or semi- gloss enamel paint, epoxy paint, FRP (Fiberglass Reinforced Panel), stainless steel, ceramic tile or other approved materials and finishes. Vinyl clad (washable) acoustical ceiling tile may be used if it is installed not less than six feet above the floor surface. **Brick, concrete block, rough concrete, rough plaster or textured gypsum boards are not acceptable.** A sample may be required for review. **(CRFC - 114271)**

5. LIGHTING:

In every room and area in which food is prepared, processed or packaged, or in which utensils are cleaned, sufficient natural or artificial lighting shall be provided to produce the following light intensity while the area is in use:

- a. At least 10-foot candles at a distance of 30 inches above the floor in walk-in refrigeration units and dry food storage areas.
- b. At least 20-foot candles at a distance 30 inches above the floor where food is provided for customer self- service; where fresh produce or prepackaged foods are sold or offered for consumption; inside equipment areas; hand washing areas; ware washing areas; equipment and utensil storage areas; and in toilet rooms.
- c. At least 50-foot candles at surfaces where a food employee is working with food or with utensils, equipment such as knives, slicers, grinders, or saws where employee safety is a factor; **and in other rooms during periods of cleaning. (CRFC - 114252)**

Light bulbs shall be shielded, coated, or otherwise shatter-resistant in areas where there are non-prepackaged ready-to-eat foods, clean equipment, utensils and linens, or unwrapped single-use articles. **(CRFC - 114252.1)**

6. VENTILATION:

Ventilation shall be provided to remove toxic gases, odor, steam, heat, grease, vapors, or smoke from the food facility including: food preparation, scullery, toilet, janitorial, garbage and change rooms. **(CRFC - 114149)**

- a. All areas of a food facility shall have sufficient ventilation to facilitate proper food storage and to provide a reasonable condition of comfort for each employee, consistent with the job performed by the employee.
- b. Toilet rooms shall be vented to the outside air by means of an openable, screened window, an airshaft, or a light-switch activated exhaust fan, consistent with the requirements of local building codes.

Mechanical Exhaust: Ventilation shall be provided over all cooking equipment such as ranges, multiple table top cooking units, broilers, fry grills, steam jacketed kettles, griddles, ovens, deep fat fryers, barbecues, rotisseries, high temperature warewashing machines (160°F rinse water), and similar equipment to effectively remove steam, heat, grease, vapors, cooking odors and smoke from the food facility. Ventilation plans for each system shall include front and side elevation of the exhaust hood and duct details to the roof fans (both exhaust and make-up air.) Provide manufacturer specification sheets for exhaust fan, make-up air fan and hood filters. Refer to the California Mechanical Code Chapter on Commercial Kitchen Ventilation Systems. Refer to CCDEH Mechanical Exhaust Ventilation Systems Operational Guidelines at www.ccdeh.org. Specify the number and location(s) of make-up air diffusers. An air balance report completed by a third party may be required prior to final clearance. Makeup air is to equal air mechanically exhausted. **(CRFC - 114149.1)**

Temperature Control: Ambient temperature of the facility shall be controlled to maintain employee comfort, to maintain refrigeration units functioning properly, and to maintain canned and jarred foods

safe. **(CRFC - 114149)** A statement regarding how ambient temperature will be controlled is required, and the locations of vents are to be shown on the plans.

7. OUTDOOR BARBEQUE/WOOD-BURNING OVEN:

Outdoor barbecues and wood burning ovens are approved provided they meet all of the following requirements as stated in the California Retail Food Code section 114143:

- The open-air barbecue or outdoor wood-burning oven is operated on the same premises as, in reasonable proximity to, and in conjunction with, a permanent food facility that is approved for food preparation. All food preparation must be conducted inside the permanent, fully enclosed food facility.
- The open-air barbecue or outdoor wood-burning oven is separated from public access to prevent food contamination or injury to the public by using ropes or other approved methods.
- If the open-air barbecue or outdoor wood-burning oven is a permanent structure, it shall be equipped with an impervious and easily cleanable floor surface that extends a minimum of five feet from the open-air barbecue or outdoor wood-burning oven facility on all open sides. More information is available on ccdeh.org.

8. FLIES, RODENT AND VERMIN EXCLUSION:

A food facility shall at all times be constructed, equipped, maintained, and operated to prevent the entrance and harborage of animals, birds and vermin, including, but not limited to, rodents and insects. **(CRFC - 114259)**

9. WINDOWS:

All windows, which can open to the outside, shall be provided with approved screening not less than sixteen (16) mesh per square inch set in tight fitting frames. **(CRFC - 114259, 114259.1)**

Pass-through windows: Pass-through window service openings shall be limited to 216 square inches each. Each opening shall be provided with a solid or screened window, equipped with a self-closing device. Screening shall be at least 16 mesh per square inch. Pass-through windows up to 432 square inches are approved if equipped with an air curtain device. Window openings must be closed when not in use. The minimum distance between the openings shall not be less than eighteen inches (18"). **(CRFC - 114259.2)**

10. EXTERIOR, EXIT, AND CARGO DOORS:

Doors shall be located and kept closed such that the food and utensil handling and storage areas, are fully enclosed at all times. **(CRFC - 114259)**

Delivery Doors: All delivery doors leading to the outside shall be outward opening and self-closing. Overhead, automatic switch- activated air curtains must be provided at delivery doors. The air curtain must be certified to NSF/ANSI Standard 37.

Exterior Doors: These include screen doors, and shall be self-closing, tight-fitting and vermin proof. Air curtains may be used as auxiliary fly control but are not adequate substitute devices to permit a door to remain open. Openings at the base and side of exterior doors shall not exceed one-fourth inch ($\frac{1}{4}$ "). All exterior wall pipes or other openings shall be tightly sealed.

Cargo Doors: Large cargo type doors can only open directly into a room where food is stored only in unopened bottles, cans, cartons, sacks, or other original shipping containers. Cargo type doors that open into any food warehouse or food facility may only be open during deliveries. In order to prevent the entry of rodents and undesirable insects, cargo type doors must be installed to be tight fitting. An air curtain is required on these types of doors to prevent the entry of flying insects and dust when the door is open. At cargo doors or delivery doors greater than 4 feet, an air curtain device is to provide an air velocity of at least 1600 feet per minute, measured 3 feet above ground level at the door opening that is activated

11. EXTERIOR VENTS AND CONDUITS:

Gaps around conduits leading to the outside, or other such openings, shall be tightly sealed. All exterior wall vents shall be properly screened with one-fourth inch (1/4") hardware cloth screening.

12. GARBAGE AREA:

Each food facility shall be provided with facilities and equipment necessary to store or dispose of all waste material. An area designated for refuse, recyclables, returnables, and a redeeming machine for recyclables or returnables is to be located so that it is separate from food, equipment, utensils, linens, and single-service and single-use articles and a public health hazard or nuisance is not created. If located within the food facility, a storage area for refuse, recyclables, and returnables shall meet the requirements for floors, walls, ceilings, and vermin exclusion. If provided, an outdoor storage area or enclosure used for refuse, recyclables, and returnables shall be constructed of nonabsorbent material such as concrete or asphalt and shall be easily cleanable, durable, and sloped to drain. **(CRFC - 114244, 114245, 114245.3, 114245.4)**

13. TOILET FACILITIES:

Each permanent food facility shall be provided with toilet rooms for employees. The number of toilet and handicapped facilities required shall be determined by the local Building Official. Toilet rooms shall be separated from other portions of the food facility by well-fitted, self-closing doors. Toilet tissue shall be provided in a permanently installed dispenser at each toilet. Toilet facilities are to have handwashing facilities, in good repair. **(CRFC 114250, 114276)**

Food facilities located within amusement parks, stadiums, arenas, food courts, fairgrounds, and similar premises shall not be required to provide toilet facilities for employee use within each food facility if the following conditions are met **(CRFC – 114276):**

- a. Approved common use toilet facilities are located within 200 feet of each food facility, and are readily available.
- b. The On-site Management office is staffed with personnel responsible for the maintenance of the designated common toilet facilities.
- c. Approved common use toilet facilities are located in a common area that will not be accessible through another business.
- d. Approval for a common use toilet facility is obtained from this Division and from the corresponding Building Official (CRFC - Chapter 8, Article 1).

Hand Washing: Hand washing facilities shall be provided within or adjacent to toilet rooms and, the number of hand washing facilities per toilet is determined by the local Building Official. See subsection titled "Hand Washing Sinks" under section 16 titled "Sinks." **(CRFC - Chapter 7, Article 10 of 18; Chapter 8, Article 1; 113952, 113953, 113953.1, 11395.2).**

14. EMPLOYEE CHANGING ROOM:

Lockers or other suitable facilities shall be located in a designated room or area where contamination of food, equipment, utensils, linens, and single-use articles cannot occur. Dressing rooms or dressing areas shall be provided and used by employees if the employees regularly change their clothes in the facility. **(CRFC - 114256)**

15. EQUIPMENT STANDARD:

All equipment shall be designed and constructed to be durable and to retain its characteristic qualities under normal use conditions. All new and replacement food-related and utensil-related equipment shall be certified or classified for sanitation by an American National Standards Institute (ANSI) accredited certification program. In the absence of an applicable sanitation certification, unique or special equipment may be evaluated for approval by this Division. All materials that are used in the construction of utensils and food contact surfaces of equipment shall not allow the migration of deleterious substances or impart colors, odors, or tastes to food, and under normal use conditions shall be safe, durable, corrosion-resistant, nonabsorbent, sufficient in weight and thickness to withstand repeated

washing, finished to have a smooth, easily cleanable surface, and resistant to pitting, chipping, crazing, scratching, scoring, distortion and decomposition. **(CRFC - 114130)**

16. SINKS:

Food facilities, which handle only pre-packaged foods, both potentially hazardous, and non-potentially hazardous, are required to provide only hand washing sinks for toilet facilities, as outlined below. All other food facilities are required to provide hand sinks in addition to all other sinks as prescribed below. **(CRFC - 113953, 113953.3)**

All sinks are to be able to provide hot (at least 120°F, at a constant pressure for at least 15 seconds) and cold running water, with the exception being hand sinks as described below. **(CRFC - 114192, 114192.1)**

Hand Washing Sinks: Food facilities constructed or extensively remodeled after January 1, 1996, that handle non-prepackaged food, shall provide facilities exclusively for handwashing in the food preparation areas and in warewashing areas that are not located within or immediately adjacent to food preparation areas. Handwashing facilities shall be sufficient in number and conveniently located, maintained clean, unobstructed and accessible at all times for use by food employees. Handwashing sinks shall have water provided from a combination or premixing faucet, which supplies warm water (at least 100°Fahrenheit) for a minimum of fifteen (15) seconds while both hands are free for washing. Automatic faucets at handwashing sinks shall be pre-set at 100-108°Fahrenheit. Handwashing facilities shall be provided with handwashing cleanser and sanitary single-use towels. **(CRFC - 113953)**

The handwashing facility shall be separated from the warewashing or food processing sink by a metal splashguard with a height of at least 6 inches that extends from the back edge of the drainboard to the front edge of the drainboard, the corners of the barrier to be rounded. No splashguard is required if the distance between the handwashing sink and the warewashing sink drainboards is 24 inches or more.

Food Preparation Sink: Food facilities are required to have a separate sink for washing, rinsing, soaking, thawing, or similar preparation of foods, and this sink shall be located within the food preparation area. The sink tub dimensions shall be at least 18" x 18" by 12" deep. An 18" x 18" drain board is to be provided. An adjacent work table of similar dimensions may be substituted for the drain board. A food preparation sink must drain indirectly through an air gap into a floor sink and must be free standing. **(CRFC - 114163)**

Manual Ware Washing Sink: All food facilities, except those that have only prepackaged items in their original unopened sealed containers, shall provide a three-compartment ware-washing sink with two integral drain boards. The sink compartments shall be large enough to accommodate immersion of the largest piece of equipment and utensils. When a sink is installed next to a wall, a metal "back splash" extending up the wall a minimum of eight (8) inches is recommended to be integral to the sink. The backsplash needs to be sealed to the wall to close any gaps between the sheet metal and wall surface. Hot and cold running water under pressure shall be provided to **each** compartment through a faucet. A sprayer may be provided in addition to a faucet. The manual ware-washing sink shall be easily accessible and conveniently located to the food preparation area. **(CRFC - 114099)**

Bar Sink (Ware Washing): A three (3) compartment bar sink with minimum dimensions of 10" X 14" X 12" with two integral metal drain boards having minimum dimensions of 10" x 14" shall be provided in bars. This sink is to be installed in the same manner as prescribed above for a manual ware washing sink.

Ware Washing Machines: Mechanical ware washing shall be accomplished by using an approved machine installed and operated in accordance with the manufacturer's specifications. Ware washing machines shall have two integral drain boards that are of adequate size and construction to each accommodate at least one ware-washing tray (e.g., 24" x 24"). Where a drain board is shared by both a three-compartment sink and a ware washing machine, the drain board is to be as long and wide as a sink compartment plus large enough to accommodate at least one ware washing machine rack. **(CRFC**

The drain boards shall be sloped and drained to an approved waste receptor. Where an under counter ware washing machine is used, there shall be two metal drain boards located adjacent to the machine. This requirement may be satisfied by using the drain boards that are part of the manual ware washing sinks if the facilities are located adjacent to the machine. **(CRFC - 114103)**

Pot and pan washers shall be equipped with drain boards or shall be equipped with approved alternative equipment that provides adequate and suitable space for soiled and clean equipment and utensils. **(CRFC - 114103)**

NOTE: Installation of a mechanical ware washing machine does not eliminate the requirement for a 3- compartment sink. (CRFC - 114101, 114103)

Rinse/Work Sink: A single compartment rinse/work sink may be provided in service areas where blenders or similar equipment are rinsed and the three-compartment sink is not located within the area. **NOTE: A Rinse/ work sink will not be a substitute for the requirement of a 3-compartment sink.**

Dump Sink: A single compartment dump sink is generally installed in bars (coffee bars, smoothie bars, and alcohol bars) for the emptying of the contents of used pitchers and glasses. A dump sink differs from a rinse/ work sink in that an assumption can be made that the beverage being disposed of has been handled by customers.

Janitorial Sink: At least one (1) of the following is to be used for general cleaning purposes and for the disposal of mop bucket wastes **(CRFC - 114279, 114281, and 114282):**

At least one curbed cleaning facility or janitorial sink equipped with hot and cold water and a drain shall be provided and conveniently located for the cleaning of mops or similar wet floor cleaning tools and for the disposal of mop water and similar liquid waste. Restricted food service facilities shall be exempt from this subdivision if hot water is available for janitorial purposes and wastewater from janitorial activities is disposed of through an approved sewage disposal system.

A room, area, or cabinet separated from any food preparation or storage area, or warewashing or storage area shall be provided for the storage of cleaning equipment and supplies.

After use, mops shall be placed in a position that allows them to air-dry without soiling walls, equipment, or supplies.

17. FOOD AND EQUIPMENT PROTECTION:

Non-prepackaged food on display and food contact surfaces shall be protected from contamination by the use of packaging, counter, service line, or sneeze guards that intercept a direct line between the consumer's mouth and the food being displayed, containers with tight- fitting securely attached lids, display cases, mechanical dispensers, or other effective means. Cafeteria, buffet and salad bar self-service, food preparation equipment and food preparation areas shall be protected by approved sneeze guards. Non-prepackaged food may be displayed and sold in bulk on other than self- service containers if the food is served by a food employee directly to a consumer. **(CRFC - 113980, 114060)**

Walk-In Refrigeration: Walk-in refrigerators shall have a well-fitted door, shall open into an approved area of the food facility, shall be constructed flush with the floor; coved base shall be provided at the intersection of floors and walls with a minimum 3/8" radius and 4" height; be flashed or sealed to walls and/or ceiling as needed to prevent rodent and vermin harborage; have non-corrodible shelving that is at least six (6) inches above the floor; shall be certified or classified for sanitation to applicable NSF/ANSI standards. Wood is not acceptable. Diamond plated flooring is not acceptable unless a trench drain is provided just outside the walk- in refrigeration door, the walk-in floor slopes 1:50 towards the trench drain, and a power wash spray method of cleaning is provided. Condensate from refrigeration units shall be

drained in a sanitary manner to a floor sink, or other approved device by an indirect connection (Please see section titled "Sewage Disposal"). Plumbing waste receptors, including floor drains, floor sinks, and evaporators are to be located outside of refrigeration units. **(CRFC - 113885, 114130, 114193)**

Equipment for cooling and heating food and for holding cold and hot food shall be sufficient in number and capacity to ensure proper food temperature control during transportation and operation. **(CRFC - 114153)**

18. INSTALLATION OF EQUIPMENT:

All equipment is to be installed in such a way that it allows for cleaning. **(CRFC - 114169)**

Equipment that is fixed because it is not easily movable shall be installed so that it is spaced to allow access for cleaning along the sides, behind, and above the equipment. Equipment must also be spaced from adjoining equipment, walls, and ceilings a distance of not more than one millimeter or one thirty-second inch. Equipment must be sealed to adjoining equipment or walls, if the equipment is exposed to spillage or seepage.

Except as specified above, floor-mounted equipment that is not easily movable shall be sealed to the floor or elevated on legs that provide at least a six-inch clearance between the floor and the equipment.

Notwithstanding this subdivision, this section shall not apply to display shelving units, display refrigeration units, and display freezer units located in the consumer shopping areas of a food facility if the floor under the units is maintained clean.

Table-mounted equipment that is not easily movable shall be installed to allow cleaning of the equipment and areas underneath and around the equipment by being sealed to the table or elevated on legs that provide at least a four-inch clearance between the table and the equipment.

19. STORAGE:

Adequate and suitable space shall be provided for the storage of food. Adequate storage generally means a minimum of 96 linear feet of 18" deep shelving. Each food facility will be evaluated on a case-by-case basis. Shelving is to be constructed to be easily cleanable. Shelves installed on a wall shall have at least a one-inch (1") open space between the back edge of the shelf or be sealed to the wall with silicone sealant or equivalent. The lowest shelf shall be at least six inches (6") above the floor with a clear, unobstructed area below. All shelves supported by legs on the floor must comply with applicable **NSF/ANSI** standards. **(CRFC - 114047)**

20. PLUMBING AND GAS:

All plumbing, plumbing fixtures, gas lines and gas-operated equipment shall be installed in compliance with local plumbing ordinances. They shall be maintained to prevent any contamination; shall be kept clean; shall be operative, and shall be in good repair. All liquid wastes shall be disposed of through the plumbing system, which shall discharge into the public sewerage or into an approved private sewage disposal system. **(CRFC - 114190)**

All steam tables, ice machines and bins, food preparation sinks, warewashing sinks, display cases, walk-in refrigerators, dipper wells for scooping ice cream and other similar equipment that discharge liquid waste shall be drained by means of indirect waste pipes, and all wastes drained by them shall discharge through an air gap into a floor sink or other approved type of receptor. Waste lines shall not cross any aisle, traffic area, or door opening. **(CRFC - 114193)**

Dipper wells plumbed with cold running water shall be provided for ice cream dipping cabinets or other similar scooping operations or by other acceptable means approved by the enforcement agency.

21. ELECTRICAL SUPPLY:

Electrical power shall be supplied at all times to operate the food facility. All electrical features and accessories shall be installed in compliance with the applicable local electrical ordinances. **(CRFC - 114182)**

22. WATER SUPPLY:

An adequate, protected, pressurized, potable supply of hot water at least 49° Celsius (120°F) measured from the faucet and cold running water shall be provided from an approved source. The potable water supply shall be protected with a backflow or back-siphon device, as required by applicable local plumbing codes.

Water Heater: Hot water generation and distribution systems shall be sufficient to meet the peak hot water demands throughout the food facility. Where fixtures are located more than sixty feet (60') from the water heater, a recirculation pump must be installed. **(CRFC - 114192, 114195)**

In sizing the water heater, the peak hourly demands for all sinks, warewashing machines, etc., are added together to determine the minimum required recovery rate. **(CRFC - 114192, 114195)**

Please provide the model number and specifications for commercial water heater as part of the application package.

Imperial County uses a 50-degree rise. See Appendix B for sizing charts. You may also refer to CCDEH's Water Heating Guideline.

Water heaters shall be installed in one of the following manners:

- On six, inch high, easily cleanable legs.
- On a four inch high coved curb base. All openings between the water heater and the base must be sealed in a watertight manner.
- On a properly finished and installed wall pedestal, positioned so that it is out of the work and traffic space.
- In an **easily accessible** location above a suspended ceiling. Where a permanently installed ladder is required to access the water heater, the ladder shall not be installed above a food or utensil handling area.

Note:

- A water heater may be approved to be installed in an area separated from food and utensil handling areas, such as in a mechanical room.
- Where fixtures are located more than sixty feet from the water heater, a recirculation pump must be installed in order to ensure that water reaches the fixture at a temperature of at least 120°F

Janitorial Sinks: These are to be protected with a permanently installed (non-removable) backflow preventer if the faucet has threads to which a hose can attach. The corresponding Building Official may require this even when there are no threads on the faucet. The faucet is to be installed above the flood rim of the janitorial sink, as directed by the corresponding Building Official.

Hose Bibs: These are to be protected with a permanently installed backflow preventer.

Produce Foggers: No fogging device installed after July 2001 shall use a reservoir for holding water for fogging, but shall employ water under pressure for fogging or misting of foods. **(CRFC - 114180)**

23. SEWAGE DISPOSAL, GREASE TRAPS AND INTERCEPTORS

A grease trap or grease interceptor shall not be located in a food or utensil handling area unless specifically approved by the enforcement agency; and shall be easily accessible for servicing. Contact the local Building department, Sanitary, or Public Works agencies for information or regulations regarding special sewerage, grease trap and grease interceptor requirements. **(CRFC - 114190, 114201)**

GUIDELINES FOR PRE-PACKAGED FOOD ONLY FACILITIES

1. The building is to be rodent-proofed. Doors leading to the outside are to be self-closing and have no more than ¼-inch gap around the perimeter of the door. Seal all holes, gaps in the walls, and ceilings. Screen window openings with tight-fitting fly screens.
2. Provide at least one restroom with a hand sink, single-use soap and paper towels, adequate lighting, proper ventilation, and a self-closing door.
3. Provide janitorial facilities including a mop sink with a backflow prevention device; shelves for storage of cleaning supplies and a mop and broom hanger.
4. Provide a minimum 10-gallon commercial hot water heater; specify the location; specify all sinks are to be supplied with hot water from this water heater. A larger capacity may be required based on the size of the facility.
5. When there is refrigeration, specify if it is self-contained or if the condensation drains to a floor sink. Walk-in refrigeration must drain to a floor sink or other approved indirect waste receptacle. Provide specifications for all refrigeration equipment and ensure that it meets ANSI certification standards.
6. Provide a finish schedule for all floor areas. Floor surfaces in the employee restrooms, janitorial areas (i.e. around the mop sink), and walk-in refrigerators shall be covered at the juncture of the floor and wall with a 3/8 inch minimum radius coving and shall extend up the wall at least 4 inches. Floor surfaces shall be smooth, durable, nonabsorbent, and easily cleanable. Flooring materials in the customer sales area and other areas are up to the discretion of the facility ownership.
7. Plans are not required for food facilities that meet the following criteria:
 - a. 300 square feet or less of food display and storage combined; **AND**
 - b. Sell or give away only prepackaged non-potentially hazardous food.

FINAL APPROVAL REQUIREMENTS

1. Once the Division has approved plans, proceed with obtaining all necessary permits and approvals from applicable agencies prior to construction.
2. Any changes to approved plans must be brought to the Division of Environmental Health's attention.
3. All construction and equipment installation is subject to on-site inspections. During the course of construction, and particularly before you plan to open, you are advised to call if you should have any questions.
4. Submit a Food Facility Health Permit Application prior to scheduling final inspection.
5. Final inspection, on-site approval, and issuance of the Health Permit are required before opening the food facility or before utilizing any remodeled areas within existing food facilities. The inspector recommends at least three (3) working days advance notice to schedule a final inspection.
6. Obtain approval prior to stocking food on the premises.

WARNING

IT IS A MISDEMEANOR VIOLATION TO BEGIN OPERATING WITHOUT A FINAL INSPECTION AND OBTAINING A VALID FOOD FACILITY PERMIT. PLEASE NOTE: IF YOU OPEN FOR BUSINESS PRIOR TO OBTAINING A FOOD FACILITY PERMIT, YOU WILL BE SUBJECT TO CLOSURE AND POSSIBLE FURTHER LEGAL ACTION. (CRFC-114381)

All facilities are subject to construction inspections, and routine, random inspections thereafter, by the Division of Environmental Health. These inspections are intended to protect the health of the public as well as the well-being of the operator by ensuring that food facilities are operated in a clean and sanitary manner with all utensils and equipment being maintained operational and in good repair. **(CRFC - 114390)**

APPENDIX A

Commercial Hoods/Mechanical Exhaust Data Sheet

(One sheet per hood)

FACILITY NAME:	DATE:
ADDRESS:	PLAN CHECK #:
PREPARED BY:	PHONE #:

Equipment To Be Placed Under Exhaust Hood:

Manufacturer	Type (Deep fryer, broiler, etc.)	Manufacturer	Type (Deep fryer, broiler, etc.)

Notes: Charcoal and other solid-fuel charbroilers require separate exhaust systems (separate exhaust duct and fan)

Exhaust Hood Specifications: **Type I** **Type II**

UL Listed (Manufacturer & model #) _____

Custom-Non-listed (Fabricator & Installer) _____ Phone # _____

Canopy Compensating Eyebrow Non-Canopy Other _____

Size of Hood Length _____ feet X Width _____ feet = _____ ft²

Exhaust CFM _____ Formula Used To Calculate CFM _____

UL listed hoods install in accordance with manufacturer as listed by UL.

Custom Hoods: Use California Mechanical Code Formula.

Number of Exhaust Ducts: _____ Size of Ducts: _____ inches X _____ inches

Square Feet of duct _____ (L x W in inches) ÷ 144

(1 duct for every 12 feet of hood length, per CMC)

Exhaust Velocity _____ FPM (Exhaust CFM ÷ Square feet of Duct)

(Duct velocity must be 500-2500 FPM per CMC)

Number of Filters _____ type of Filters _____ Size of Filters(inches): L _____ X W _____

Rating of Filters _____ fpm

Make-up Air Supply

Make-up Air CFM _____ (MUA for custom hoods must equal exhaust CFM; MUA for listed hoods must be as specified by Manufacturer)

Number of registers _____ Two (2) or more strongly recommended for all hoods and spaced so as not to short-circuit

Notes: Make-up air and Hood Exhaust must be electrically interconnected on one switch.
Windows and Outside doorways are Not Acceptable for makeup air.

APPENDIX B

Commercial Water Heater Worksheet

Calculate the required recovery rate in gallons per hour (GPH)

- Tankless Water Heaters please refer to Water Heater Guidelines located at ccdeh.org

Hourly Hot Water Demand Table

Compartment Size	Gallons Per Compartment	Compartment Size	Gallons Per Compartment
16" X 20" →	14	18" X 30" →	23
18" X 18" →	14	20" X 28" →	24
18" X 24" →	19	24" X 24" →	25
18" X 26" →	20	24" X 30" →	31

- Dish machines/Glasswashers: Bar Refer to manufacture specs for GPH and minimum water temperature inputs
- Sink (12" X 12"): 6 gallons per compartment
- Food Prep Sink: 5 gallons per compartment
- Janitorial Sink: 15 gallons per sink
- Garbage Can Wash Facility: 15 gallons per facility
- Hand sink(s): 5 gallons per sink
- Pre-Rinse Hand Spray: 45 gallons (if other type, refer to manufacture specifications)
- 9 & 12 pound washers: 45 gallons
- 16 pound washers: 60 gallons
- Employee Shower: 20 gallons
- For all others: Refer to manufacture specifications

- A. The following examples are provided to explain how to calculate the total hourly hot water demand:
1. Food facility that utilizes only single service eating and drinking utensils.

Assume:

Number	Type	Demand
1	Three compartment sink (18"x18")	42 GPH
2	Hand lavatories	10 GPH (5 GPH each)
1	Janitorial sink	15 GPH
	Total	67 GPH

67 GPH X 80% allowance for single service utensils = 54 GPH. For the food facility in this example, a water heater would be required, which will recover 54 GPH. A gas water heater that provides a minimum of 30,000BTU's or an electric water heater that provides 7KW would meet the requirement.

2. Food facility that utilizes multiservice eating and drinking utensils:

Assume:

Number	Type	Demand
1	Three compartment sink (18"x18")	42 GPH
1	Automatic dish machine	80 GPH
1	Hand spray	45 GPH
1	Food prep sink	5 GPH
2	Hand lavatories	10 GPH (5 GPH each)
1	Janitorial sink	15 GPH
	Total	197

Since the food facility in this example uses multiservice eating and drinking utensils, 100% of the computed hourly hot water demand must be provided. Therefore, a water heater would be required, which will recover 197 GPH. A commercial gas water heater that provides a minimum of 110,000BTU's or a commercial electric water heater that provides 25KW would meet the requirement.

Sizing Table for Gas Water Heaters

Gallons Per Hour Delivery At Indicated Temperature Rise

BTU (X 1000)	40°F	50°F	60°F	70°F
5	11	9	8	6
10	23	18	15	13
15	34	27	23	19
20	45	36	30	26
25	56	45	38	32
30	68	54	45	39
35	79	63	53	45
40	90	72	60	51
45	101	81	68	58
50	113	90	75	64
55	124	99	83	71
60	135	108	90	77
65	146	117	98	84
70	158	126	105	90
75	169	135	113	96
80	180	144	120	103
85	191	153	128	109
90	203	162	135	116
95	214	171	143	122
100	225	180	150	129
105	236	189	158	135
110	248	198	165	141
115	259	207	173	148
120	270	216	180	154
125	281	225	188	161
130	293	234	195	167
135	304	243	203	174
140	315	252	210	180
145	326	261	218	187
150	338	270	225	193
155	349	279	233	199
160	360	288	240	206
165	371	297	248	212
170	383	306	255	219
175	394	315	263	225
180	405	324	270	232
185	416	333	278	238
190	428	342	285	244
195	439	351	293	251
200	450	360	300	257
205	461	369	308	264
210	473	378	315	270
215	484	387	323	277
220	495	396	330	283
225	506	405	338	289
230	518	414	345	296
235	529	423	353	302
240	540	432	360	309
245	551	441	368	315
250	563	450	375	322

Sizing Table for Electric Water Heaters

Gallons Per Hour Delivery At Indicated Temperature Rise

KW	40°F	50°F	60°F	70°F
1	10	8	7	6
2	20	16	13	11
3	30	24	20	17
4	40	32	27	23
5	50	40	33	29
6	60	48	40	34
7	70	56	47	40
8	80	64	54	46
9	90	72	60	52
10	100	80	67	57
11	110	88	74	63
12	120	96	80	69
13	130	104	87	75
14	141	112	94	80
15	151	120	100	86
16	161	128	107	92
17	171	136	114	97
18	181	145	120	103
19	191	153	127	109
20	201	161	134	115
21	211	169	141	120
22	221	177	147	126
23	231	185	154	132
24	241	193	161	138
25	251	201	167	143
26	261	209	174	149
27	271	217	181	155
28	281	225	187	161
29	291	233	194	166
30	301	241	201	172
31	311	249	207	178
32	321	257	214	184
33	331	265	221	189
34	341	273	227	195
35	351	281	234	201
36	361	289	241	206
37	371	297	248	212
38	381	305	254	218
39	391	313	261	224
40	401	321	268	229
41	411	329	274	235
42	422	337	281	241
43	432	345	288	247
44	442	353	294	252
45	452	361	301	258
46	462	369	308	264
47	472	377	314	270
48	482	385	321	275
49	492	393	328	281
50	502	401	335	287

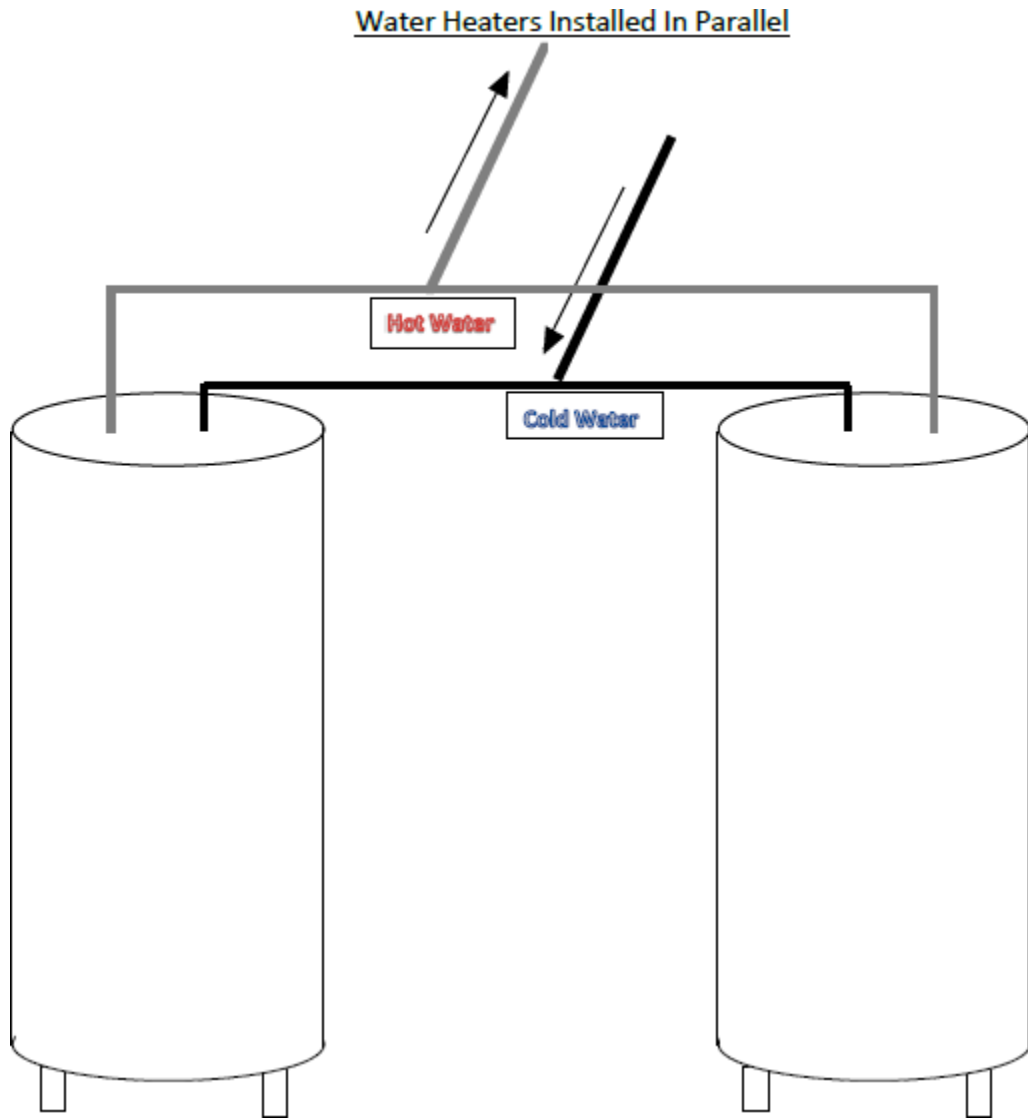

APPENDIX C

Sample Floor Plan- Restaurant

NOT DRAWN TO SCALE

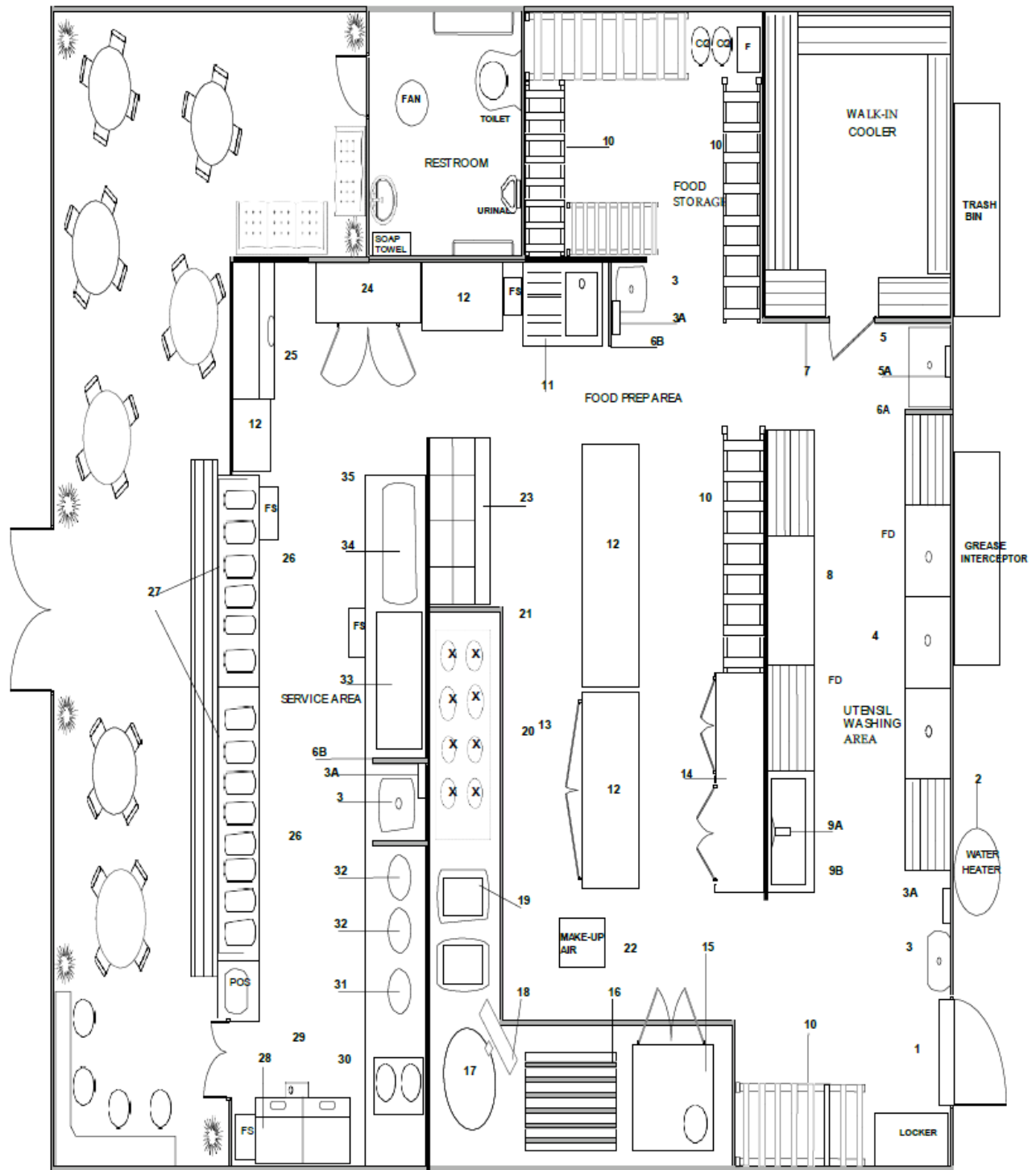

- LEGENDS**
- FS- FLOOR SINK
 - FD- FLOOR DRAIN

DBA _____
ADDRESS: _____

Equipment Schedule Sample

#	EQUIPMENT	MANUFACTURER MODEL NO.	NSF	PLUMBING				COMMENT
				HW	CW	DIR	FS	
1	DOOR ACTIVATED AIR CURTAIN							1600 fpm
2	COMMERCIAL GAS WATER HEATER							90,000 BTU
3	(3) HANDWASHING SINKS		X	X	X	X		
3A	SOAP & TOWEL DISPENSERS							
4	MANUAL WAREWASHING 3-COMPARTMENT SINK 18" x 18" x 12"		X	X	X		X	(2) 18" drain boards
5	MOP BASIN			X	X	X		Approved backflow prevention device
5A	MOP & BROOM HANGER							Wall-mounted chemical storage shelf
6A	18" S/S SPLASHGUARD							
6B	6" S/S SPLASHGUARD							
7	WALK-IN COOLER		X				X	
8	LOW TEMP. MECHANICAL WAREWASHING MACHINE		X	X			X	
9A	PRE-RINSE FAUCET		X		X			
9B	PRE-RINSE SINK		X				X	
10	METRO SHELVES Minimum: (1)-8'; (3)-6'; (1)-5'; (1)-4'		X					5 tiers Dry food storage
11	FOOD PREP SINK (18" x 18" x 12")		X	X	X		X	18" drain board
12	FOOD PREP TABLE		X					
13	2-DOOR UNDERCOUNTER REFRIGERATOR		X					Self-contained
14	4-DOOR UPRIGHT FREEZER		X					Self-contained
15	DOUBLE CONVECTION OVEN		X					
16	RADIANT CHARBROILER		X					
17	TILTING KETTLE		X	X	X			Indirect waste
18	TRENCH/TROUGH DRAIN							
19	(2) FRYERS		X					
20	8 BURNER STOVE		X					
21	TYPE I HOOD		X					UL - LISTED
22	MAKE-UP AIR							Electronically interlocked with hood
23	SANDWICH PREP TABLE		X					Self-contained
24	2 DR UPRIGHT REFRIG.		X					Self-contained
25	ICE MACHINE		X		X		X	
26	(2) STEAM TABLE		X				X	
27	SNEEZE GUARD		X					See elevation F12
28	DIPPING CABINET		X				X	
29	DIPPER WELL		X		X		X	
30	COFFEE BREWER		X					
31	COFFEE GRINDER		X					CSA
32	(2) BLENDERS		X					
33	SODA DISPENSER		X		X		X	ETL
34	ESPRESSO MACHINE		X		X		X	
35	STAINLESS STEEL TABLE		X					

Equipment Schedule

NO.	EQUIPMENT DESCRIPTION	FLOOR BASE	MANUFACTURER MODEL NO.	PLUMBING					COMMENTS
				NSF	HW	CW	DIR	FS	

Address: _____ DBA: _____		FINISH SCHEDULE	Date: _____ Owner's Name: _____	
AREA	FLOOR		FLOOR BASE	WALL

APPENDIX D

Approved Floor Coverings

Commercial Grade Sheet Vinyl

1. Inlaid commercial grade sheet vinyl with a minimum thickness of 0.085 gauge.
2. Flooring should continue up all walls, partitions, counters or cabinetry at least four inches high forming an integral 3/8 inch radius cove base.
3. All seams should be heat welded or chemically sealed to form a continuous surface.
4. Non-skid or abrasive sheet vinyl should be limited to traffic areas only.

Quarry or Ceramic Tile

1. The grout spacing between tiles should not exceed 1/4 inch and should be sealed.
2. Flooring should continue up all walls, partitions, counters or cabinetry at least four inches high forming an integral 3/8 inch radius cove base.
3. Non-skid or abrasive tiles should be limited to traffic areas only.

Troweled Epoxy Type Floor

1. Minimum finish thickness should be 3/16 inch.
2. The surface should be sealed to be impervious to water, grease and acid.
3. Flooring should continue up all walls, partitions, counters or cabinetry at least four inches high forming an integral 3/8 inch radius cove base.
4. Non-skid flooring with an abrasive texture should be limited to traffic areas only. Sanitary Cove Base and floor surface areas under equipment should be smooth.

Sealed Concrete

1. The floor should be smooth, single pour variety.
2. The floor should be sealed with a USDA approved two part catalyzed water based epoxy concrete floor sealer.
3. Concrete floors with open seams, pitted, chipped, or rough surface areas should be repaired prior to sealing concrete.
4. Flooring should continue up all walls, partitions, counters or cabinetry at least four inches high forming an integral 3/8 inch radius cove base.
5. A ceramic covered tile base may be used if keyed into floor surface so that it is flush with the sealed concrete (see image below).

FLOOR COVING

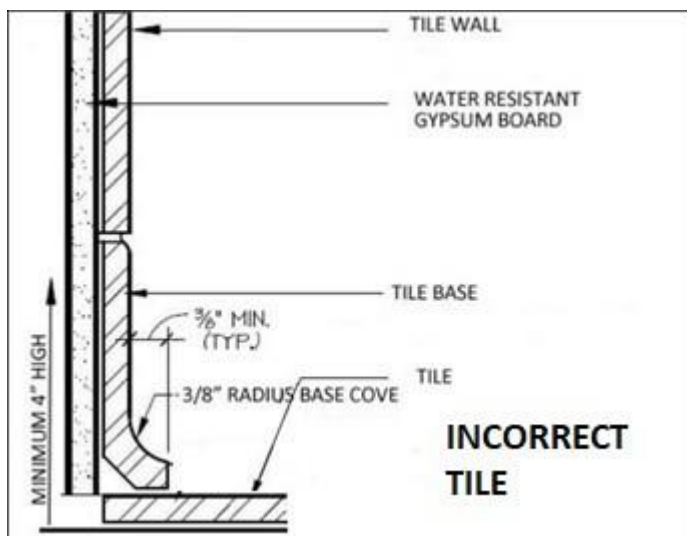
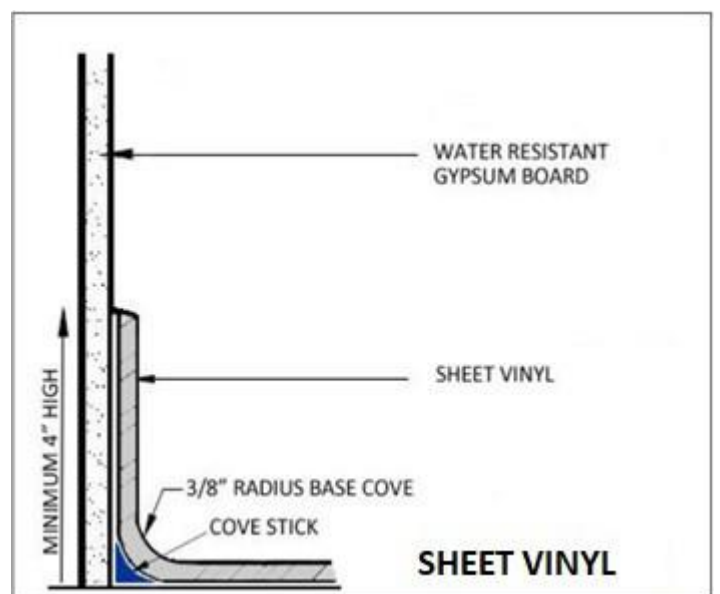
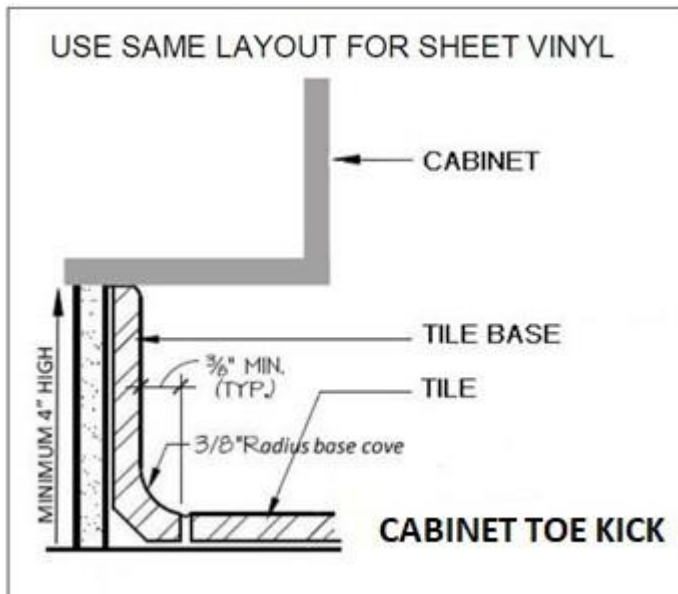
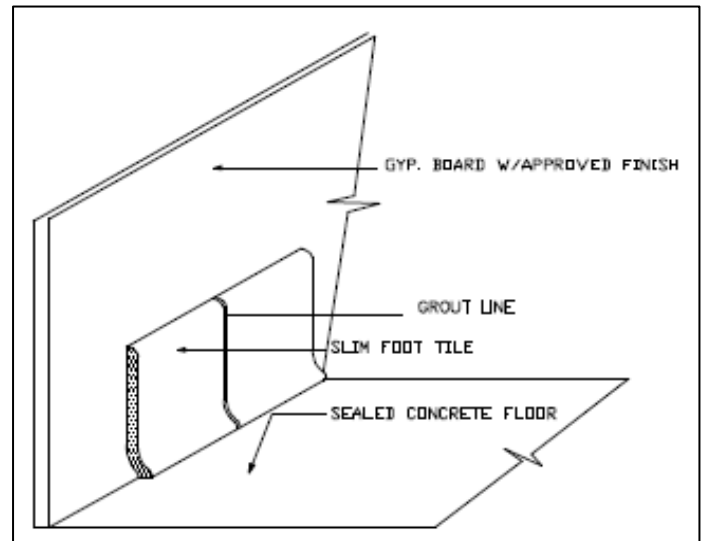
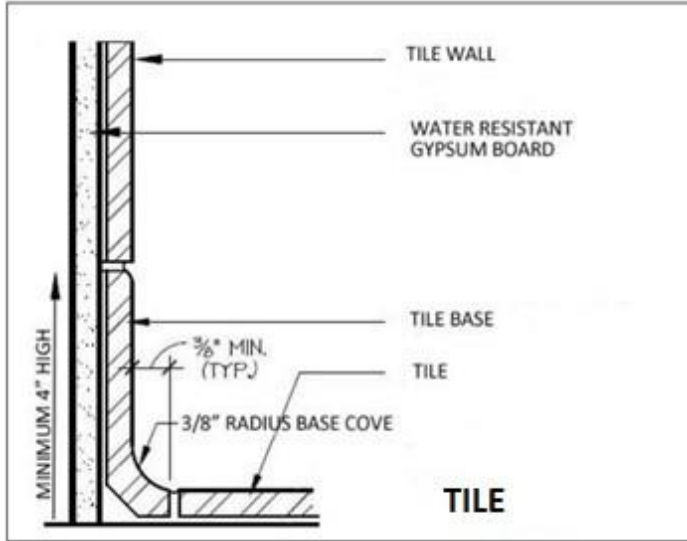

APPENDIX E

Plan Submittal Construction/Remodel Checklist

The intent of this form is to assist the applicant in submitting a complete plan. A complete plan submittal allows the Environmental Health staff to perform the review at maximum efficiency. This form is for the applicant's personal use. For detailed information, regarding requirements please refer to the California Retail Food Code.

UNPACKAGED RETAIL FOOD FACILITY CRITERIA:

Y	N	N/A	
<input type="checkbox"/>	<input type="checkbox"/>	<input type="checkbox"/>	Three identical sets of plans
<input type="checkbox"/>	<input type="checkbox"/>	<input type="checkbox"/>	Site plan showing locations of food facility & refuse storage
<input type="checkbox"/>	<input type="checkbox"/>	<input type="checkbox"/>	Floor plan drawn to scale, readable, and in ink
<input type="checkbox"/>	<input type="checkbox"/>	<input type="checkbox"/>	All equipment drawn to scale on floor plan and labeled
<input type="checkbox"/>	<input type="checkbox"/>	<input type="checkbox"/>	Equipment schedule with make and model numbers
<input type="checkbox"/>	<input type="checkbox"/>	<input type="checkbox"/>	Finish schedule for all areas
<input type="checkbox"/>	<input type="checkbox"/>	<input type="checkbox"/>	Food menu
<input type="checkbox"/>	<input type="checkbox"/>	<input type="checkbox"/>	Storage shelving (min. 96 linear ft.)
<input type="checkbox"/>	<input type="checkbox"/>	<input type="checkbox"/>	Employee changing room or lockers
<input type="checkbox"/>	<input type="checkbox"/>	<input type="checkbox"/>	Detailed exhaust hood drawings, including plan view, elevations & CFMs
<input type="checkbox"/>	<input type="checkbox"/>	<input type="checkbox"/>	Three compartment sink with integral drain boards
<input type="checkbox"/>	<input type="checkbox"/>	<input type="checkbox"/>	Food preparation sink with drainboard or adjacent table
<input type="checkbox"/>	<input type="checkbox"/>	<input type="checkbox"/>	Hand washing sink(s)
<input type="checkbox"/>	<input type="checkbox"/>	<input type="checkbox"/>	Janitorial Sink
<input type="checkbox"/>	<input type="checkbox"/>	<input type="checkbox"/>	Water heater location and proposed energy input (KW, BTU, or Gallons Per Hr.)
<input type="checkbox"/>	<input type="checkbox"/>	<input type="checkbox"/>	Employee restroom(s)
<input type="checkbox"/>	<input type="checkbox"/>	<input type="checkbox"/>	Public restroom(s), if required

PREPACKAGED RETAIL FOOD FACILITY CRITERIA:

Y	N	N/A	
<input type="checkbox"/>	<input type="checkbox"/>	<input type="checkbox"/>	Three identical set of plans
<input type="checkbox"/>	<input type="checkbox"/>	<input type="checkbox"/>	Site plan showing locations of food facility & refuse storage
<input type="checkbox"/>	<input type="checkbox"/>	<input type="checkbox"/>	Floor plan drawn to scale, readable, and in ink
<input type="checkbox"/>	<input type="checkbox"/>	<input type="checkbox"/>	All equipment drawn on floor plan and labeled
<input type="checkbox"/>	<input type="checkbox"/>	<input type="checkbox"/>	Equipment schedule with make and model numbers
<input type="checkbox"/>	<input type="checkbox"/>	<input type="checkbox"/>	Finish schedule
<input type="checkbox"/>	<input type="checkbox"/>	<input type="checkbox"/>	Storage shelving
<input type="checkbox"/>	<input type="checkbox"/>	<input type="checkbox"/>	Janitorial sink
<input type="checkbox"/>	<input type="checkbox"/>	<input type="checkbox"/>	Water heater location and proposed energy input (KW, BTU, or Gallons Per Hr.)
<input type="checkbox"/>	<input type="checkbox"/>	<input type="checkbox"/>	Employee restroom(s)
<input type="checkbox"/>	<input type="checkbox"/>	<input type="checkbox"/>	Public restroom(s), if required